

# K50 Slotted Stainless Steel Grate Spec Sheet

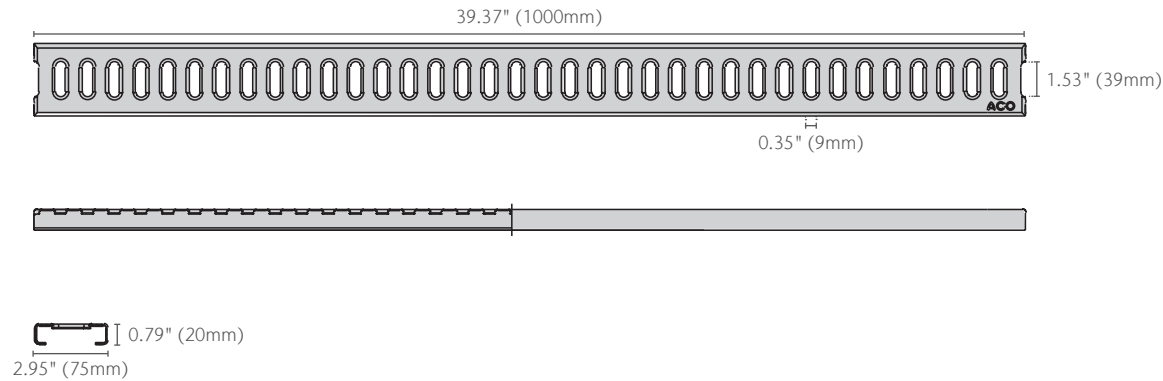

## K50 Slotted Stainless Steel Grate

part no. 95545



Product Name	Part No.	Length in (mm)	Width in (mm)	Weight lbs
K50 Slotted Stainless Steel Grate	95545	39.37 (1000)	2.95 (75)	4.0

### Specification Summary

#### General

The surface drainage system shall be ACO Drain MiniKlassik K50/KS50 channels complete with ACO MiniKlassik K50 Slotted Stainless Steel Grate as manufactured by ACO, Inc. or similar approved.

#### Installation

The trench drain system and grates shall be installed in accordance with the manufacturer's installation instructions and recommendations.

#### Materials

The covers shall be manufactured from stainless steel and have minimum properties as follows:

- 16 gauge, grade 304 stainless steel
- Intake area of 18.7 in<sup>2</sup> (120.6 cm<sup>2</sup>) per meter grate

The overall width of 2.95" (75 mm) and overall length of 39.37" (1000 mm). Slots measure 1.35" (34 mm) by 0.38" (10 mm).



Australian Standard AS 3996 - 2006 Clause 3.3.6: max slot length dependent on slot width for grates that are deemed Bicycle Tire Penetration Resistant.



EN1433 Load Class A  
3,372 lbs – 70 psi

### ACO, Inc.

© January 2026 ACO, Inc.

All reasonable care has been taken in compiling the information in this document. All recommendations and suggestions on the use of ACO products are made without guarantee since the conditions of use are beyond the control of the company. It is the customer's responsibility to ensure that each product is fit for its intended purpose and that the actual conditions of use are suitable. ACO, Inc. reserves the right to change products and specifications without notice.

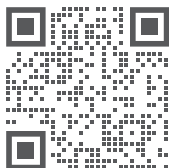

info@acousa.com  
www.acousa.com

